

Layout the location and the length of the wall required as per project drawings. Excavate the base trench as shown in the wall base detail.

Note: When using a 24 square foot block see A Block wall base detail.
When using a 12 square foot block see A.5 Block wall base detail.

Information on this page is a guideline only and must be approved or modified by the project engineer to suit site specific conditions

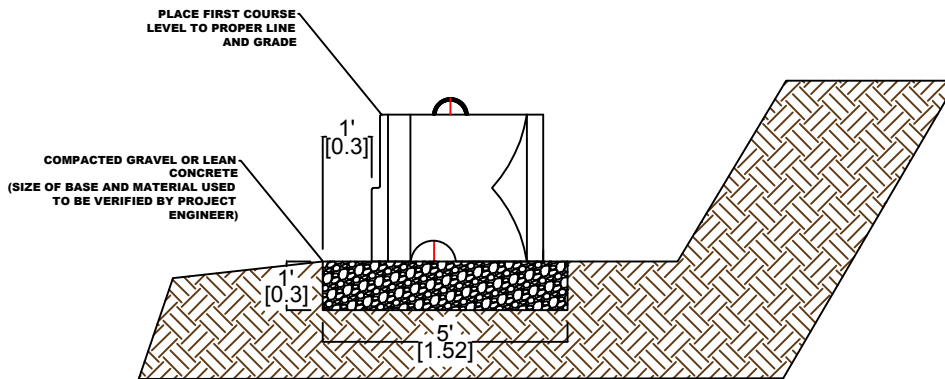

A BLOCK WALL BASE DETAIL

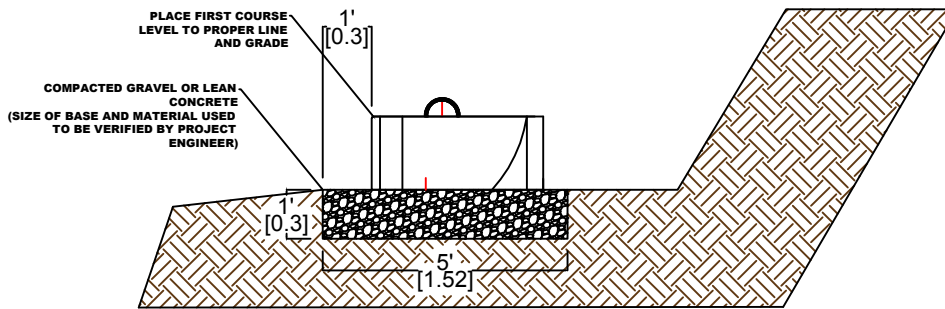

A.5 BLOCK WALL BASE DETAIL

TITLE
WALL BASE INSTALLATION GUIDELINE

PROJECT
RETAIN-A-ROCK INSTALLATION GUIDELINES

DATE DEC. 27.10	DRAWN BY GKH	CHECKED BY	REVISED
---------------------------	------------------------	-------------------	----------------

DC **DESIGN CONCRETE SYSTEMS LIMITED**
63 BIRCH STREET, SEAFORTH ONTARIO
N0K 1W0 CANADA
PHONE (519) 527-0397
FACSIMILE (519) 527-2325
designconcrete.ca

JOB NUMBER

DRAWING NUMBER
BASE1

Always start the wall base at the lowest elevation of the wall if possible. Set wall elevations using a laser level and stakes prior to excavating.
This will make the wall installation much more efficient.

Note: When using a 24 square foot block see A Block wall base detail.
 When using a 12 square foot block see A.5 Block wall base detail.

Information on this page is a guideline only and must be approved or modified by the project engineer to suit site specific conditions

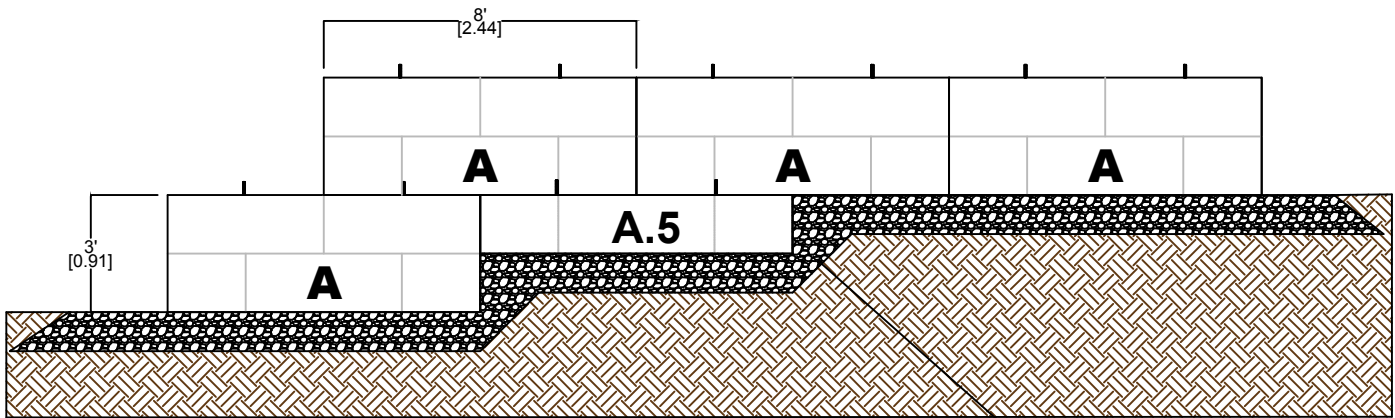

A BLOCK WALL BASE STEP DETAIL

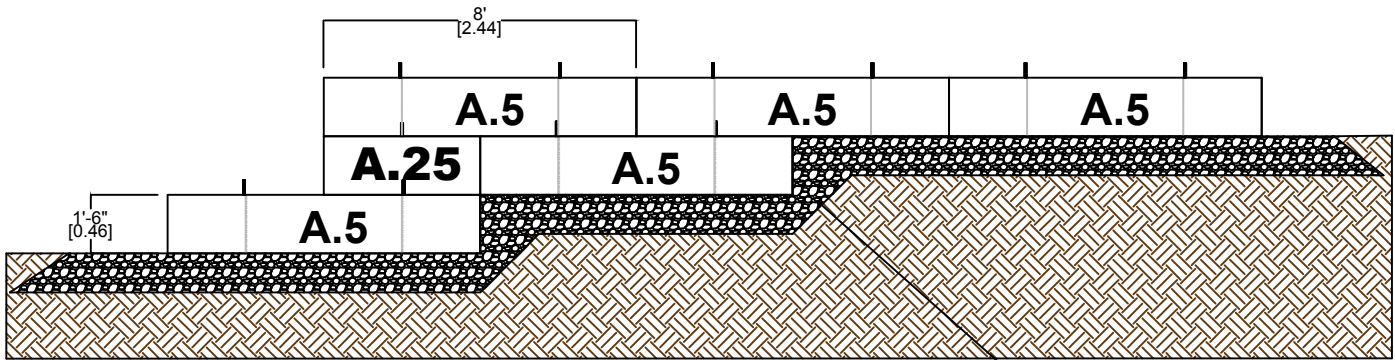

A.5 BLOCK WALL BASE STEP DETAIL

TITLE
WALL BASE STEP INSTALLATION GUIDELINE

PROJECT
RETAIN-A-ROCK INSTALLATION GUIDELINES

DATE DEC. 27.10	DRAWN BY GKH	CHECKED BY	REVISED
---------------------------	------------------------	-------------------	----------------

DC DESIGN CONCRETE SYSTEMS LIMITED
 63 BIRCH STREET, SEAFORTH ONTARIO
 N0K 1W0 CANADA
 PHONE (519) 527-0397
 FACSIMILE (519) 527-2325
 designconcrete.ca

JOB NUMBER

DRAWING NUMBER
 BASE2

Fill in voids between block using 19mm clear crushed stone. Other materials to be verified by project engineer before use. The fill helps to lock the blocks together. An estimated 1.3 cubic metres is required per 24 square foot rock. Fill behind the rock to be as per site engineer. A minimum of 6" is recommended. Filter cloth may be used to separate the backfill from the native soil. The best filling practice is to alternate between filling the blocks and the backfill in 8" lifts. This will limit migration and protect the filter cloth (if applicable). Compact fill to engineer's requirements. Only small compactor units should be used within 3" of the rocks. Clean off the top of each course to ensure a proper fit for the next course.

Information on this page is a guideline only and must be approved or modified by the project engineer to suit site specific conditions

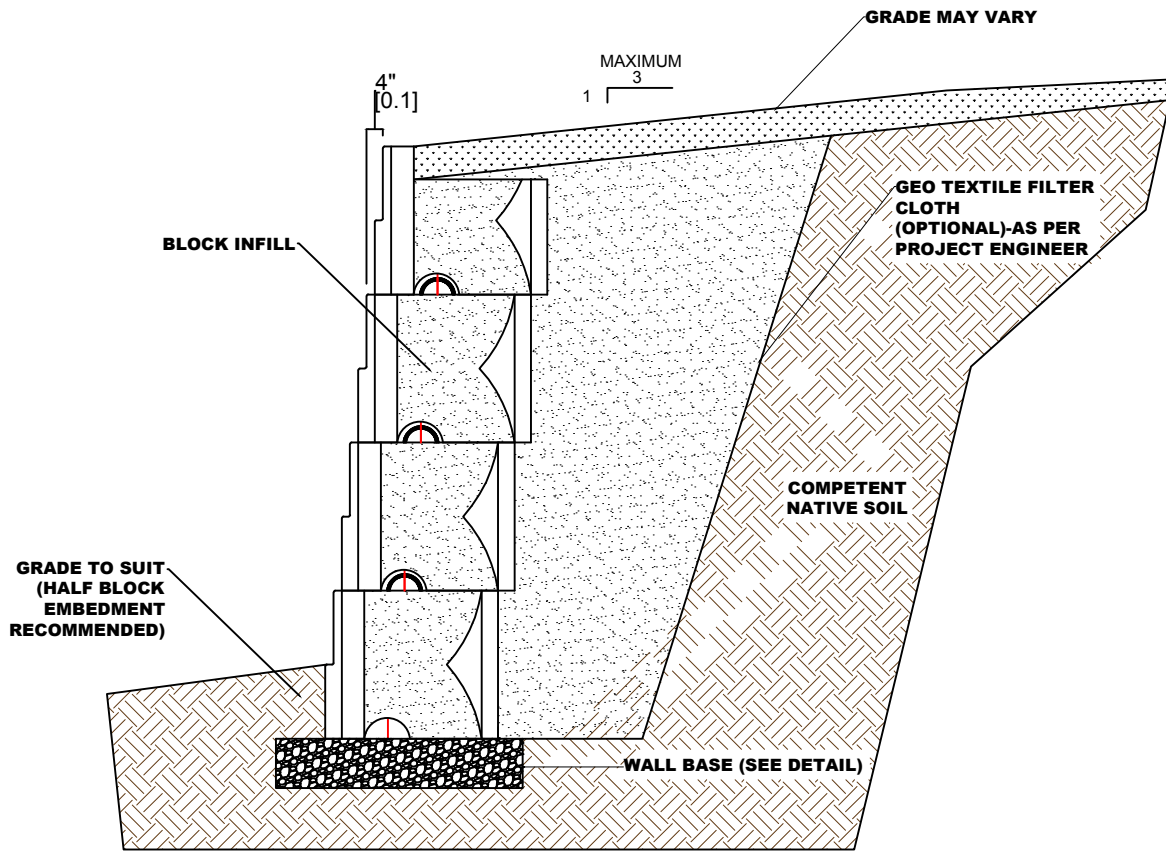

GRAVITY WALL CROSS SECTION

TITLE
GRAVITY WALL INSTALLATION GUIDELINE

PROJECT
RETAIN-A-ROCK INSTALLATION GUIDELINES

DATE DEC. 27.10	DRAWN BY GKH	CHECKED BY	REVISED
---------------------------	------------------------	-------------------	----------------

DC **DESIGN CONCRETE SYSTEMS LIMITED**
 63 BIRCH STREET, SEAFORTH ONTARIO
 N0K 1W0 CANADA
 PHONE (519) 527-0397
 FACSIMILE (519) 527-2325
 designconcrete.ca

JOB NUMBER

DRAWING NUMBER
FILL1

Taller or walls with high stresses may require soil reinforcement. This can be achieved using a geo grid behind the Retain-A-Rock system. Consult a geotechnical engineer for site specific details. Excavate soils in the reinforced soil area to the proper depth and length. Install geo grid as shown and according to engineer's specifications. Install geo grid with the axis running perpendicular to the face of the wall. Level ground is beneficial when laying the geo grid. Use standard compaction procedures after geo grid placement. Install between layers of Retain-A-Rock as required. Use caution when using machinery. Do not turn sharp or make sudden stops that could damage the geo grid material.

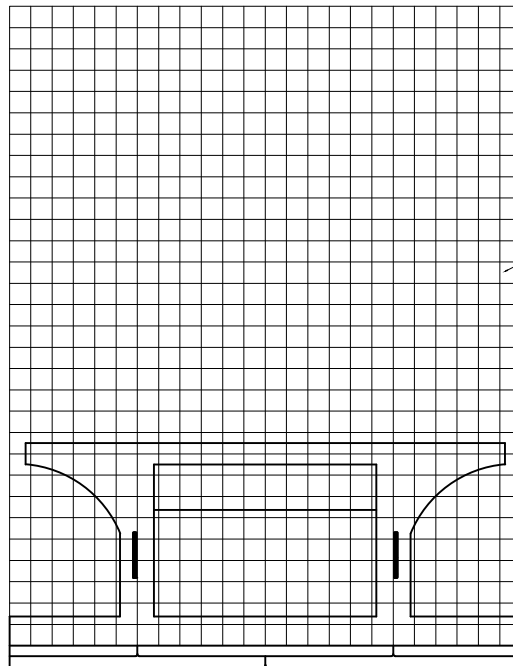

ALIGN MACHINE DIRECTION OF GEO GRID PERPENDICULAR TO WALL FACE

EXTEND GEO GRID TO FACE OF BLOCK

Information on this page is a guideline only and must be approved or modified by the project engineer to suit site specific conditions

GEO GRID INSTALLATION

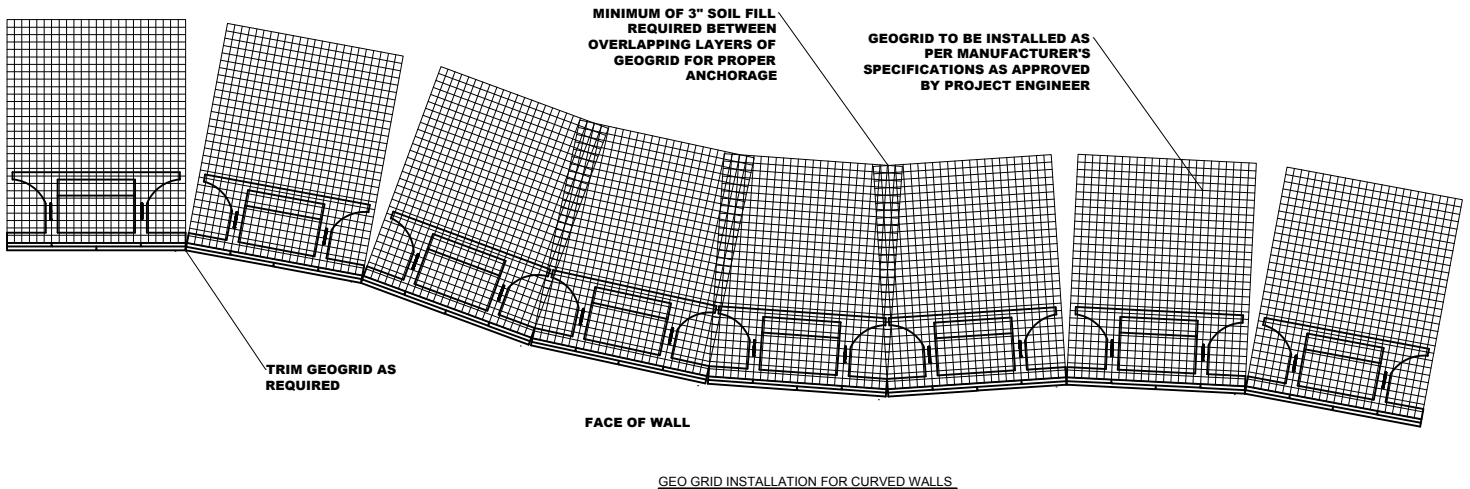

MINIMUM OF 3" SOIL FILL REQUIRED BETWEEN OVERLAPPING LAYERS OF GEOGRID FOR PROPER ANCHORAGE

GEOGRID TO BE INSTALLED AS PER MANUFACTURER'S SPECIFICATIONS AS APPROVED BY PROJECT ENGINEER

TRIM GEOGRID AS REQUIRED

FACE OF WALL

GEO GRID INSTALLATION FOR CURVED WALLS

TITLE
GEO GRID INSTALLATION GUIDELINE

PROJECT
RETAIN-A-ROCK INSTALLATION GUIDELINES

DATE DEC. 27.10	DRAWN BY GKH	CHECKED BY	REVISED
---------------------------	------------------------	-------------------	----------------

DESIGN CONCRETE SYSTEMS LIMITED
63 BIRCH STREET, SEAFORTH ONTARIO
N0K 1W0 CANADA
PHONE (519) 527-0397
FACSIMILE (519) 527-2325
designconcrete.ca

JOB NUMBER

DRAWING NUMBER
GEOGRID1

BASE COURSE NOTES

Use caution when excavating. Do not excavate beyond required depth for trench. Level the wall base with either well compacted gravel, or lean concrete as per the project engineer's specifications. It is recommended to compact a gravel base to no less than 95% Standard Proctor. Lean concrete can be used and is recommended on projects that are tall or have bad soil conditions. It may also improve installation time, but cost may be a factor. Additional trench depth may be required for units that are below grade. Consult project engineer for clarification. The trench for the base should be a minimum of 60" (1.53m). In ground units are best to have landscape fabric placed underneath and up the sides of the blocks to aid in drainage over time. The units provide internal drainage, therefore it is important to ensure that there is proper drainage at the base. Consult the geotechnical engineer if more drainage is required.

Information on this page is a guideline only and must be approved or modified by the project engineer to suit site specific conditions

TITLE

BASE NOTES

PROJECT

RETAIN-A-ROCK INSTALLATION GUIDELINES

DATE

DEC. 27.10

DRAWN BY

GKH

CHECKED BY

REVISED



**DESIGN CONCRETE
SYSTEMS LIMITED**
63 BIRCH STREET, SEAFORTH ONTARIO
N0K 1W0 CANADA
PHONE (519) 527-0397
FACSIMILE (519) 527-2325
designconcrete.ca

JOB NUMBER

DRAWING NUMBER

NOTES1

Minimum Convex Radius Per Course

Wall Height	# of Courses	Top Radius ft. (m)
6	2	52'0" (15.85)
9	3	52'4" (15.95)
12	4	52'8" (16.05)
15	5	53'0" (16.15)
18	6	53'4" (16.25)
21	7	53'8" (16.35)
24	8	54'0" (16.45)

CONVEX RADIUS

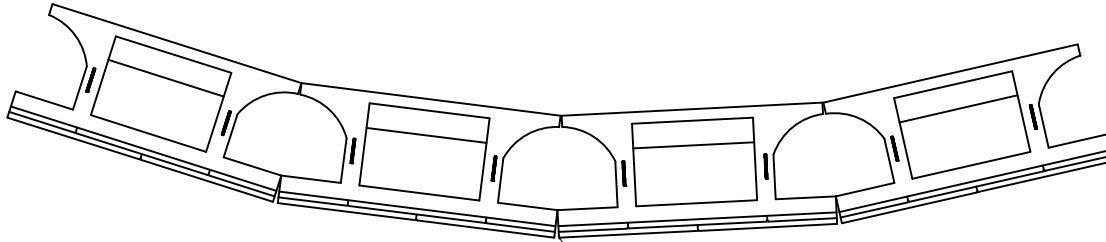

**RADIUS 51'8" (15.75m)
MINIMUM (SEE SCHEDULE)**

Place the first Retain-A-Rock units using the hooks. Make sure the units are touching. The first course is the most important. Ensure that all units are level.

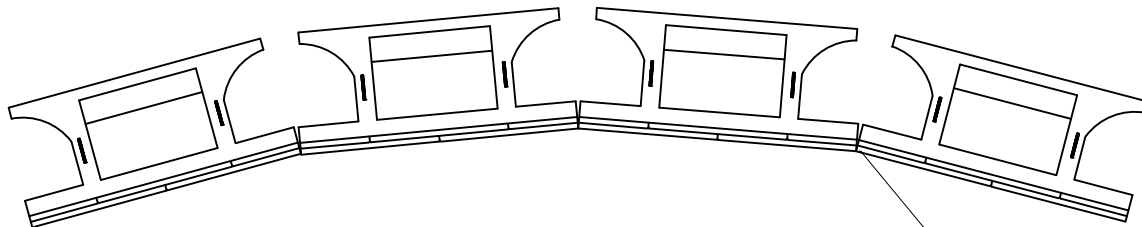

CONCAVE RADIUS

**RADIUS 45' (13.72m)
MINIMUM (SEE SCHEDULE)**

Minimum Concave Radius Per Course

Wall Height	# of Courses	Top Radius ft. (m)
6	2	46'4" (14.12)
9	3	46'8" (14.22)
12	4	47'0" (14.33)
15	5	47'4" (14.43)
18	6	47'8" (14.53)
21	7	48'0" (14.63)
24	8	48'4" (14.73)

TITLE
RADIUS GUIDELINES

PROJECT
RETAIN-A-ROCK INSTALLATION GUIDELINES

DATE DEC. 27.10 **DRAWN BY** GKH **CHECKED BY** **REVISED**

DC **DESIGN CONCRETE SYSTEMS LIMITED**
63 BIRCH STREET, SEAFORTH ONTARIO
N0K 1W0 CANADA
PHONE (519) 527-0397
FACSIMILE (519) 527-2325
designconcrete.ca

JOB NUMBER

DRAWING NUMBER
RADIUS1

Set second course of A blocks as shown, placing the first block of the second course at half bond to the one below. Blocks will align automatically with the rebar hooks. Install remaining blocks in the same fashion. If geo textile is required, follow job specific details. Stepping the top of the wall is an option, depending on site details. One example is shown below. Each project is unique and wall can be tailored to suit specific layouts.

Information on this page is a guideline only and must be approved or modified by the project engineer to suit site specific conditions

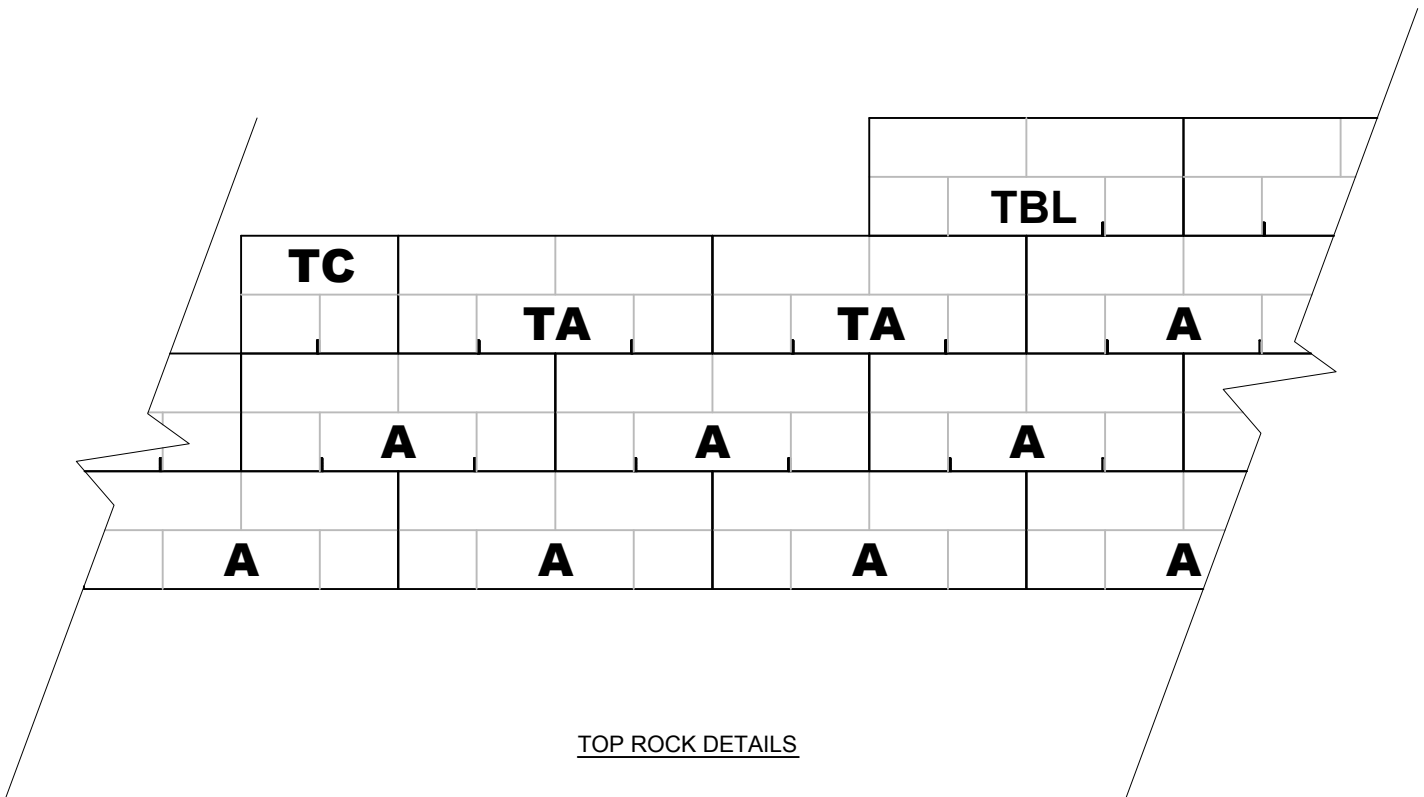

TITLE
TOP INSTALLATION GUIDELINES

PROJECT
RETAIN-A-ROCK INSTALLATION GUIDELINES

DATE DEC. 27.10	DRAWN BY GKH	CHECKED BY	REVISED
---------------------------	------------------------	-------------------	----------------

DC **DESIGN CONCRETE SYSTEMS LIMITED**
63 BIRCH STREET, SEAFORTH ONTARIO
 NOK 1W0 CANADA
 PHONE (519) 527-0397
 FACSIMILE (519) 527-2325
 designconcrete.ca

JOB NUMBER

DRAWING NUMBER
TOP1

RETAIN-A-ROCK TOP ROCK (TA/TC/TD...) IS DESIGNED TO FINISH THE TOP OF THE WALL AND ALLOW FOR GRADE TO BE TAKEN RIGHT TO THE FRONT FACE OF THE WALL.

Information on this page is a guideline only and must be approved or modified by the project engineer to suit site specific conditions

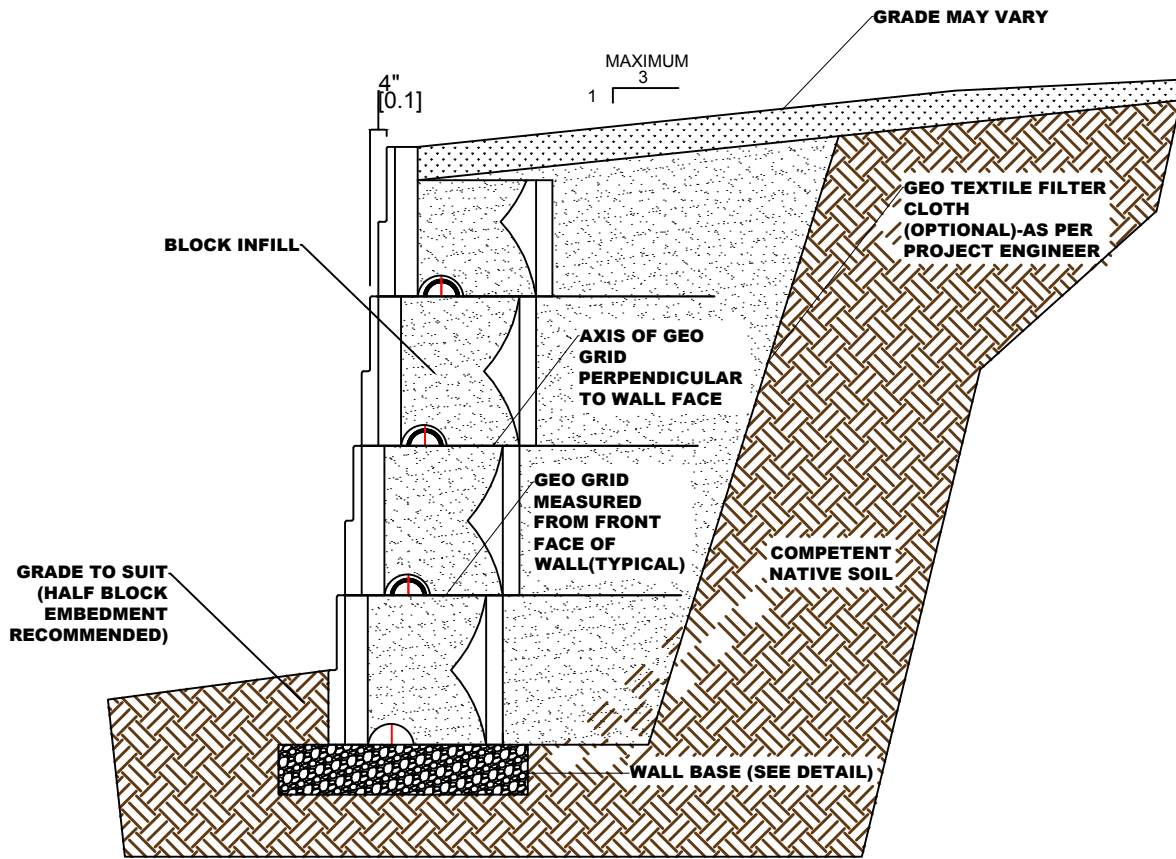

TOP WALL WITH GEO GRID CROSS SECTION

TITLE
TOP INSTALLATION GUIDELINES

PROJECT
RETAIN-A-ROCK INSTALLATION GUIDELINES

DATE DEC. 27.10	DRAWN BY GKH	CHECKED BY	REVISED
---------------------------	------------------------	-------------------	----------------

DC DESIGN CONCRETE SYSTEMS LIMITED
 63 BIRCH STREET, SEAFORTH ONTARIO
 N0K 1W0 CANADA
 PHONE (519) 527-0397
 FACSIMILE (519) 527-2325
 designconcrete.ca

JOB NUMBER

DRAWING NUMBER
TOP2